

# 275/K12RM 900-1200



## REMOVABLE ANTITERRORISM BOLLARDS

The removable 275/K12RM bollards are typically used to prevent the parking, transit and access of unauthorised vehicles in sensible sites.

It is advised that the removable bollard is used only if the amount of daily movements is limited (if not, the automatic version should be used) or when the depth of installation does not allow for the installation of the automatic bollards.



Anticorrosion marine treatment



# 275/K12RM 900-1200



## AVAILABLE ITEMS

BOLLARD 275/K12RM FEV – NORMAL STEEL PAINTED equipped with standard EU lock with 2 keys

BOLLARD 275/K12RM IXV – STAINLESS STEEL (AISI 304) PAINTED equipped with standard EU lock with 2 keys

BOLLARD 275/K12RM IXS – STAINLESS STEEL (AISI 304) BRUSHED equipped with standard EU lock with 2 keys

NORMAL STEEL PAINTED BASEMENT TO BE FIXED INTO THE GROUND

CYLINDER IN AISI 316 STAINLESS STEEL

SQUARE CROWN DEVICE FOR BASEMENT (MOUNTING SET)

The squared perimeter crown has the same dimension of the automatic version

CYLINDER PAINTING IN ANY RAL COLOR

ADDITIONAL COST FOR EU PROFILE LOCK WITH IDENTICAL KEYS

ADDITIONAL KEY FOR EU LOCK

ADDITIONAL HEAD FOR 275/K12RM BOLLARD

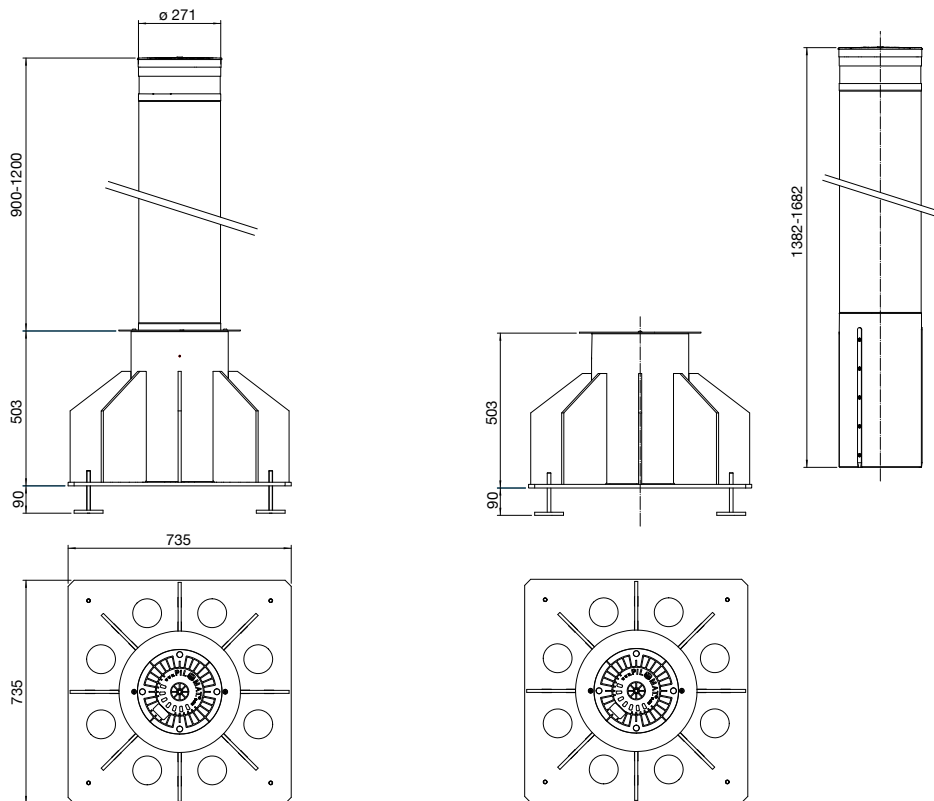

PAG.2/3

**PILOMAT**  
**HÖRMANN**  
100% MADE IN ITALY

PILOMAT s.r.l.

www.pilomat.com | pilomat@pilomat.com  
Via Zanica 17/p, 24050, Grassobbio (BG) Italy  
Tel. +39.035.29.72.20

Copyright 2022© Pilomat S.r.l. All rights reserved

REVIEW 11/07/2022

Information in this document is for reference only. In pursuit of its policy of continuous refinement and improvement, Pilomat reserves the right to amend this information at any time and without prior notice.  
Picture shown is for illustration purpose only.

# 275/K12RM 900-1200



	275/K12RM 900	275/K12RM 1200
CYLINDER MATERIAL	S235JR NORMAL STEEL - X5CrNi 18-10 (AISI 304) STAINLESS STEEL - X5CrNiMo 17-12-2 (AISI 316) STAINLESS STEEL	
CYLINDER DIAMETER	271mm	
CYLINDER HEIGHT	900mm	1200mm
CYLINDER THICKNESS	23mm	
CYLINDER NORMAL STEEL FINISH	ANTI-CORROSION TREATMENT - GREY ANTHRACITE STANDARD PAINTING	
CYLINDER STAINLESS STEEL FINISH	GREY ANTHRACITE STANDARD PAINTING OR BRUSHING	
REFLECTING ADHESIVE STRIP	STANDARD - HEIGHT 55mm	
IMPACT RESISTANCE (WITHOUT DEFORMATION)	250.000 J	
BREAKOUT RESISTANCE	2.000.000 J	
SECURITY LOCK	STANDARD - EUROPEAN PROFILE HALF CYLINDER ACCORDING TO DIN 18252 3 KEYS INCLUDED	
CYLINDER WEIGHT (WITHOUT BASEMENT)	199 Kg	243 Kg
BASEMENT WEIGHT	184 Kg	
PERIMETRAL CROW (CIRCULAR)	INCLUDED IN THE SUPPLY	
ANTI-CORROSION TREATMENT "M"	OPTIONAL TO BE ORDERED IN CASE OF INSTALLATIONS THAT ARE LESS THAN 2 KM FROM THE SEA TO BE ORDERED IN CASE OF INSTALLATIONS WHERE SALT IS USED ON THE ROAD TO AVOID ICE FOR A PERIOD UP TO 3 MONTHS	

