

275/K12 900SA-1200SA



SEMI-AUTOMATIC BOLLARD WITH MANUALLY OPERATED HYDRAULIC UNIT

The 275/K12 900SA and 275/M50 1200SA semiautomatic bollards have been designed to ensure the anti-terrorist protection. Current models are the result of our 40 years' experience in the security field and in excess of 20 years in the specific design and manufacture of automatic bollards.

The installation of the 275/K12 bollard is recommended for use in any security sensitive site like company driveways, industrial driveways, research centres, embassies, police facilities, military bases.



275/K12 900SA-1200SA



AVAILABLE ITEMS

BOLLARD 275/K12 FEV - NORMAL STEEL PAINTED

BOLLARD 275/K12 IXV - STAINLESS STEEL PAINTED

BOLLARD 275/K12 IXS - STAINLESS STEEL BRUSHED

FOUNDATION BOX IN ALUZINC FOR 275/K12 - COUNTERFRAME AND REBARS
ONE FOUNDATION BOX FOR EACH BOLLARD

MULTILED LIGHTING STRIP- 25 LED POINTS

REFLECTING ADHESIVE STRIP - WHITE (NO-LOGO)

HEAD WITHOUT LOGO FOR 275/K12

PAINTING WITH RAL COLOUR ON REQUEST

AISI 316 STAINLESS STEEL CYLINDER

SECURITY LOCK FOR MECHANICAL LOCKING OPERATING POINT

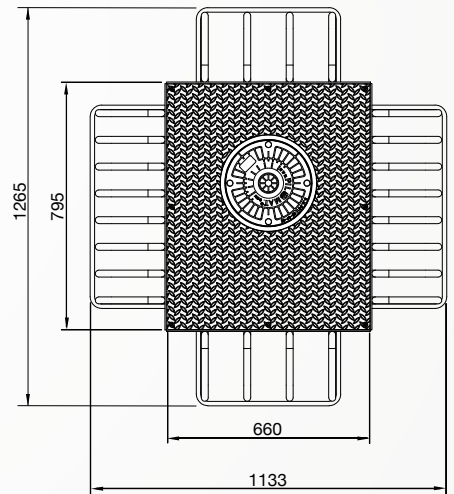
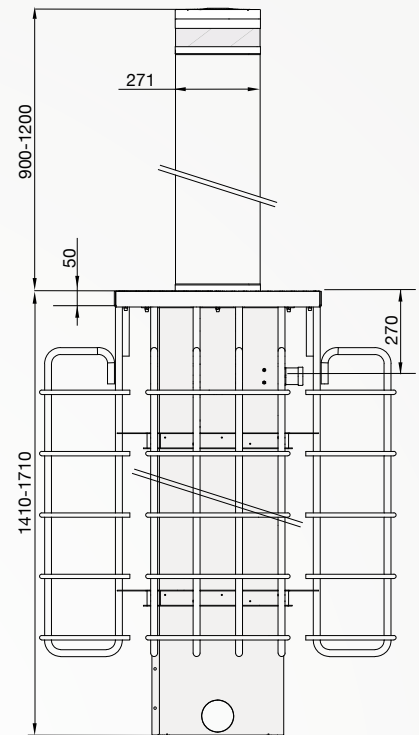

PAG.2/3

PILOMAT
HÖRMANN
100% MADE IN ITALY

PILOMAT s.r.l.
www.pilomat.com / pilomat@pilomat.com
Via Zanica 17/p, 24050, Grassobbio (BG) Italy
Tel. +39.035.29.72.20
Copyright 2022© Pilomat S.r.l. All rights reserved

REVIEW 12/07/2022

Information in this document is for reference only. In pursuit of its policy of continuous refinement and improvement, Pilomat reserves the right to amend this information at any time and without prior notice.
Picture shown is for illustration purpose only.

275/K12 900SA-1200SA



	275/K12-900SA	275/M50-1200SA
CYLINDER MATERIAL	S355JR NORMAL STEEL X5CrNi 18-10 (AISI 304) / X5CrNiMo 17-12-12 (AISI 316) STAINLESS STEEL	
CYLINDER DIAMETER	271mm	
CYLINDER HEIGHT	900mm	1200mm
CYLINDER THICKNESS	23mm	
OPERATING PRINCIPLE	MANUAL - WITH BATTERY DRILL RISING: CLOCKWISE ROTATION - LOWERING: COUNTERCLOCKWISE ROTATION	
CYLINDER NORMAL STEEL FINISH	ANTI-CORROSION TREATMENT - GREY ANTHRACITE STANDARD PAINTING	
CYLINDER STAINLESS STEEL FINISH	GREY ANTHRACITE STANDARD PAINTING OR BRUSHING	
OTHER CYLINDER FINISH	KNURLING	
REFLECTING ADHESIVE STRIP	STANDARD - HEIGHT 55mm	
RISING TIME (WITH BATTERY DRILL RECOMMENDED)	8cm/s	
LOWERING TIME (WITH BATTERY DRILL RECOMMENDED)	20cm/s	
MANUAL HYDRAULIC UNIT	BUILT-IN INTO THE BOLLARD	
PROTECTION CLASS	IP67	
IMPACT RESISTANCE (WITHOUT DEFORMATION)	700.000 J	
BREAKOUT RESISTANCE	2.000.000 J	
NOMINAL OPERATING TEMPERATURE	-40 °C +70 °C	
ANTI-CORROSION TREATMENT "M"	OPTIONAL ORDER IN CASE OF INSTALLATION AT LESS THAN 2KM FROM THE SEA ORDER IN CASE OF INSTALLATION WHERE SALT IS USED ON THE ROAD TO AVOID ICE FOR A PERIOD UP TO 3 MONTHS	
CORDLESS DRILL/DRIVER RECOMMENDED	OPTIONAL - Bosch GSR 18V-60C Professional or equivalent	
DRILL INSERT FOR LIFTING/LOWERING	STANDARD-1 PIECE INCLUDED	
CONNECTION LINE FOR FLASHING LIGHT (OPTIONAL)	STANDARD 10M (MAX. 80M)	
CONNECTION LINE FOR HEATING RESISTANCE (OPTIONAL)	STANDARD 10M - (MAX. 50M)	
LOAD CLASS (EN124)	D400	
CERTIFIED	PAS68:2013 V/7500(N3)/80/90:9.3/29.1 IWA14-1:2013V/7200(N3C)/80/90:9.6 ASTM F2656/F2656M-20C750/7200 P3	PAS68:2013 V/7500(N3)/80/90:1.4/8.0 ASTM F2656-07 M50 (K12)

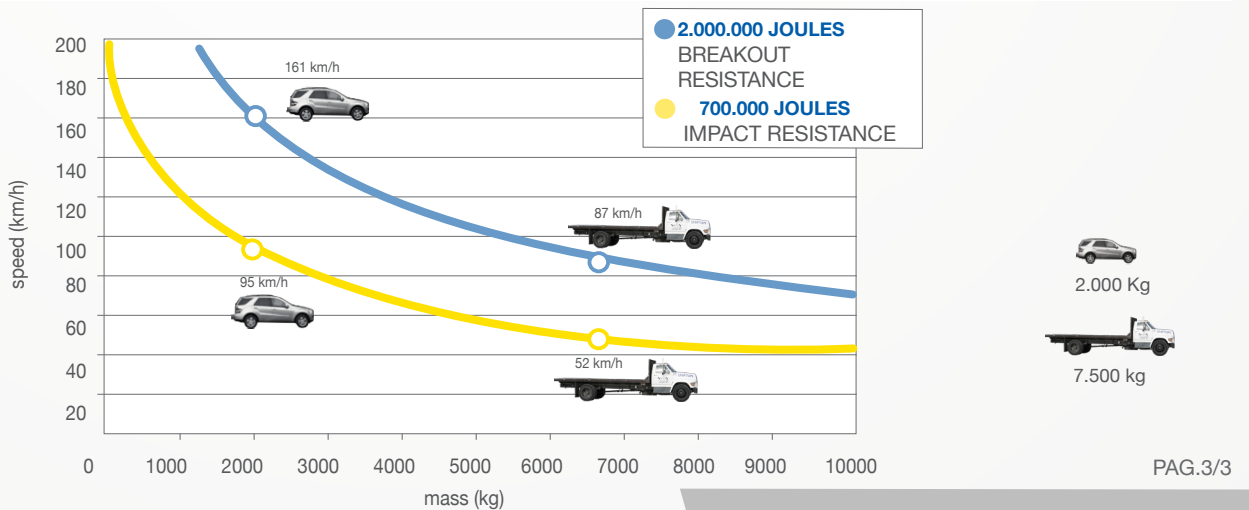

PILOMAT
HÖRMANN
100% MADE IN ITALY

PILOMAT s.r.l.
www.pilomat.com / pilomat@pilomat.com
Via Zanica 17/p, 24050, Grassobbio (BG) Italy
Tel. +39.035.29.72.20
Copyright 2022© Pilomat S.r.l. All rights reserved

REVIEW 12/07/2022

Information in this document is for reference only. In pursuit of its policy of continuous refinement and improvement, Pilomat reserves the right to amend this information at any time and without prior notice.
Picture shown is for illustration purpose only.